

Technical Paper

BR-1959

Investigative Approach to Address Thermoacoustic Vibration in Gas-Fired Heaters and Boilers

Authors:

S. Rufener

T.A. Fuller

T.J. Flynn

Babcock & Wilcox

Akron, Ohio, USA

M. Whelan

John Zink Company

Tulsa, Oklahoma, USA

C.E.A. Finney

Oak Ridge National Laboratory

Oak Ridge, Tennessee, USA

J. O'Connor

T. Dare

Pennsylvania State University

University Park, Pennsylvania,

USA

Presented to:

AFRC 2022 Industrial

Combustion Symposium

Date:

September 12-14, 2022

Location:

Greenville, South Carolina, USA



INVESTIGATIVE APPROACH TO ADDRESS THERMOACOUSTIC VIBRATION IN GAS-FIRED HEATERS AND BOILERS †

Suzana Rufener, Timothy A. Fuller and Thomas J. Flynn
The Babcock & Wilcox Company
Akron, Ohio, USA

Matt Whelan
John Zink Company, LLC
Tulsa, Oklahoma, USA

Charles E.A. Finney
Oak Ridge National Laboratory
Oak Ridge, Tennessee, USA

Jacqueline O'Connor and Tyler Dare
The Pennsylvania State University
University Park, Pennsylvania, USA

ABSTRACT

Industrial gas-fired boilers, furnaces and heaters occasionally encounter low-frequency vibrations generated by dynamic feedback between the burner (or burners) and acoustic modes in adjacent cavities in the main combustion chamber or ductwork. Feedback occurs when pressure pulses associated with acoustic resonances propagate to the burner so that they are in phase with combustion rate fluctuations. When the combustion and acoustic fluctuations become sufficiently phase-synchronized, normal sources of dissipation may be insufficient to dampen the combined pressure waves, resulting in amplifications that may reduce thermal efficiency, increase emissions, and eventually cause structural damage. In the literature, such oscillations are referred to as thermoacoustic oscillations or ‘rumble,’ and their basic physics have been the subject of numerous investigations for well over a century. Although it occurs relatively infrequently, rumble poses a significant challenge because it is difficult to predict, diagnose, and resolve. The underlying relationships involved are sufficiently complex that it is possible for two apparently identical boilers or furnaces to exhibit completely different rumble tendencies. In previous work, we reviewed common sources of rumble and how nonlinear signal analyses, such as bivariate mutual information and transfer entropy, could be used to locate both its sources and impact in boilers, furnaces, and heaters.

Thermoacoustic vibration is more difficult to predict than flow induced vibration due to the complicated resonance coupling of the burner and combustion cavity. Often, vibration concerns can be addressed by minor adjustments to burner settings, damper settings (acoustic damping), or to the furnace enclosure stiffness to reduce vibration amplitudes. However, these changes often can only be identified through a time-consuming trial and error approach. In previous papers, [Flynn (2017), and Flynn (2018)], the current knowledge about the causes of thermoacoustic vibrations in industrial natural-gas-fired furnaces and boilers was summarized, and opportunities for enhancing diagnosis and remediation were identified. Herein, we review pertinent references, discuss the issue of thermoacoustic-induced vibrations in more detail for gas-fired boilers, and apply some of the previously suggested nonlinear analysis techniques, such as bivariate mutual information and time irreversibility. Dare [(2018)] performed analysis on signal data collected from a gas-fired package boiler to characterize thermoacoustic vibration. Whelan [(2019)] suggested a combination of a simplified analysis and practical mitigation techniques to address thermoacoustic vibration.

† **Note:** Significant components of the introductory and methodology descriptive text herein are included verbatim from our papers from previous AFRC meetings [Flynn, 2017 and Flynn, 2018]. We choose this approach of verbatim inclusion over reference to make this paper self-contained in its narrative, in case of limited availability of the cited papers. Compared with earlier papers, the present paper expands its focus on application with additional case studies, and adds analytical methodology, with different results and conclusions.

This paper will further describe an improved method to either predict the potential of thermoacoustic vibration or diagnose the root cause on an existing heater or boiler. An approach is suggested to address thermoacoustic vibration on commercial natural gas package boilers using a combination of acoustic finite element analysis (FEA) modeling and analysis of field data. Experience and field data from past episodes of thermoacoustic vibration are integrated into the acoustic FEA modeling.

INTRODUCTION

The Babcock & Wilcox Company (B&W), a supplier of boilers and combustion system for more than 150 years, has gathered data and conducted research into understanding the phenomenon of thermoacoustic vibration. B&W has partnered with The Pennsylvania State University (Penn State) and its Applied Research Laboratory (ARL) to identify and mitigate the thermoacoustic instability on industrial package boilers. B&W has also initiated a partnership with Oak Ridge National Laboratory (ORNL) to further analyze the data collected on package boilers. The John Zink Company has extensive experience supplying combustion systems for industrial boilers and investigating thermoacoustic vibration. John Zink Company and B&W have a commercial collaboration for marketing and selling package boiler systems to industry and utility customers.

BACKGROUND

The source of thermoacoustic vibrations (rumble) in industrial furnaces and boilers is distinct from flow-induced vibration and is more closely related to the ‘singing flame’ phenomenon in heated tubes, which has been studied in various forms since the 18th century [Richardson (1922)]. Thermoacoustic vibrations always require the presence of two key features: 1) a large temperature gradient, and 2) a gas-filled cavity capable of supporting Helmholtz resonances [Chanaud (1994), Seebold (2005), Balasubramanian & Sujith (2008), Eisinger & Sullivan (2002, 2008)]. The underlying physics of this phenomenon was originally explained by Rayleigh [(1878)], who noted that the key requirement for sustained vibrations is met when the rate of change in pressure in the vicinity of a flame or hot surface becomes directly correlated with the rate of heat input (either via reaction or transfer from a hot surface). More recently, Nicoud and Poinsot [(2005)] suggested that the requirement for vibrations in combustion systems is also met when the rate of temperature rise becomes directly correlated with the reaction rate. In either case, the key requirement is to have synchronized phasing between the rate of heat input and the rate of gas compression/expansion.

In some of the most definitive studies to date, Eisinger and Sullivan [(2002, 2008)] showed that large temperature differentials between the cold burner inlet air and the hot combustion gases can lead to such phase synchronization in industrial-scale furnaces and boilers. Other key factors are the lengths of the burner cavity and the hot gas zones, which provide the necessary spatial domains and boundary conditions for the development of standing acoustic (pressure) waves that can be excited by input heat energy. Two common standing-wave patterns that originate in the burner are referred to as either the Rijke or Sondhauss modes, which are named after their original experimental discoverers [Balasubramanian (2008), Rott (1983), Eisinger & Sullivan (2002, 2008)]. Synchronization occurs when there is constructive interference between these standing waves and downstream resonances in the post-burner hot zone. When this happens, thermal energy from combustion is converted into acoustic energy. Under normal operation, furnaces and boilers typically have large temperature differentials between the hotter product gases and the cooler reactant air, thus there is a large thermal energy source to sustain these oscillations once they begin.

Eisinger and Sullivan presented a map that delineates operating and design regions where synchronization is likely in furnaces and boilers. As shown in **Figure 1**, two dimensionless parameters, representing the key geometric and temperature factors, are used to determine whether any given system falls into the stable (non-vibrating) or unstable (vibrating) region. Typical load isotherms are plotted relative to these regions in **Figure 1** for a wide range of burner and furnace system geometries. As can be seen in the figure, thermoacoustic instability tends to increase with load for many different geometric configurations.

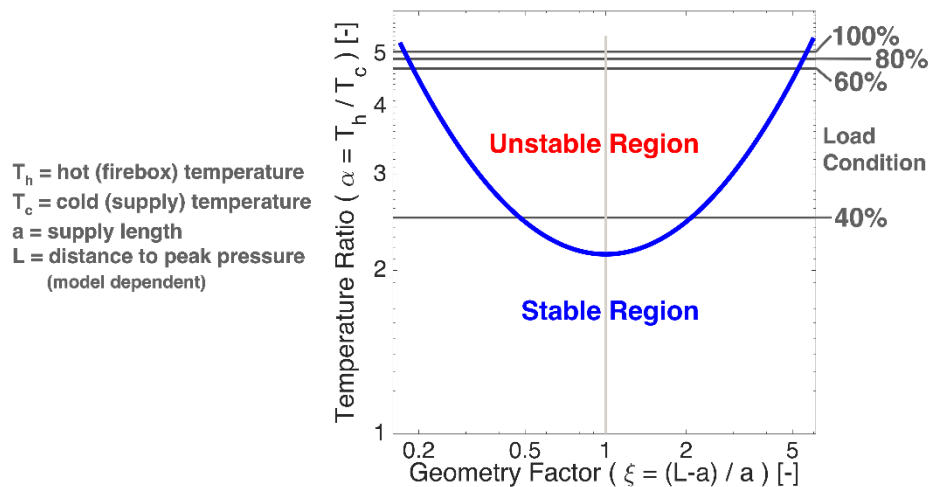

Figure 1. Thermoacoustic vibration stability curve [after Eisinger and Sullivan (2008)] with typical load isotherms.

Often the key geometric factors responsible for thermoacoustic vibrations in a specific unit are difficult to identify because of the complex interaction of firebox and duct design characteristics that can be involved in the standing-wave patterns. Rumble also often appears during specific types of operating transients or load states (typically at intermediate or part load states), so it may not always be observed until after a unit has been initially constructed and tested. This intermittent nature can also make rumble difficult to characterize and correlate with operational events. It is not uncommon for two “identical” boilers, that one unit will exhibit vibration while the other will not at apparently identical operating conditions. Although much work has been done to characterize thermoacoustic vibration in combustion systems, slight variations in design may still yield unanticipated vibrations.

Fuel variations can also be involved in the appearance of rumble. Many industrial boilers have a single burner that is designed to fire a variety of fuels, including natural gas, #6 or #2 oil, syngas, biogas or waste gas depending on which fuel is most readily available at the lowest cost. Although natural gas is currently the lowest cost fuel, its composition can vary significantly depending on the source, and non-price driven supply issues can also result in fueling shifts. Substitution of hydrogen could also have unanticipated effects. Whatever the cause, the specific combustion properties of different fuels can have a significant impact on combustion and heat release and thus promote or suppress the onset of rumble.

When rumble occurs, it is sometimes possible to make operational adjustments (e.g., changing burner settings or avoiding certain firing rates) that directly improve the burner or acoustic parameters themselves or that suppress the interactive feedback; in some instances, disrupting standing acoustic waves is a strategy [Seebold (2005)]. In many cases, however, operating adjustments are not sufficient to solve the problem, and it may only be possible to take measures that reduce the resulting vibrational damage (e.g., adding mechanical stiffeners to vibrating components) rather than removing the original source of the problem. Ideally, if our understanding of the rumble phenomenon is sufficient, it should be preferable and less costly to remove the underlying causes by more effectively avoiding certain design features and/or developing and implementing more effective active control measures that suppress feedback. For the latter, it might even be possible to add such controls to existing units. In the following sections, we summarize the information currently available in the literature about both of these possible approaches. We also believe it is important to consider methods that might be used for diagnosing rumble in individual cases to better identify root causes and thereby reduce the cost and time associated with resolving the problem. We illustrate possible approaches for the latter with example field data collected from a boiler experiencing rumble.

Thermoacoustic vibrations can occur in a wide range of combustion systems operating in both fuel-lean or fuel-rich conditions, as long as the conditions necessary for constructive interference between heat input and acoustics are met. Fuel-lean conditions are often chosen to minimize nitrogen oxides (NO_x) emissions in combustion turbines, and these tend to shift the main heat-release zone upstream into the burner throat while also reducing the temperature of the post-burner gases. Both of these changes affect the relative locations of the heat release and acoustic (pressure) waves. Excessively lean operation can also lead to flame lifting, which leads to transient shifts in the flame location and length that cause jumps back and forth across the stability boundary in Figure 1 (e.g., see Daw (2002)). Fuel-rich conditions coupled with air staging are often chosen for industrial boilers to minimize NO_x emissions, but these can also lead to longer and cooler flames, shifts in the speed of sound, and corresponding shifts in acoustic wave lengths.

Studies of Thermoacoustic-Induced Vibrations

Rodriguez-Martinez et al. [(2006)] studied instabilities in a partially premixed swirl burner and furnace test rig. The testing also included the effect of the inlet air duct geometry on the instabilities. Low-frequency (30–100 Hz) instabilities were characterized. Unstable pressure amplitudes greater than 5% of the mean pressure were observed. They concluded that the instabilities result from excitation of the longitudinal modes of the air supply ducting which formed the dominant acoustic geometry of their test rig. They note that their test rig exhibits similar behavior to that observed in pulse combustors, dump combustors, and gas turbines where the flame dynamics are strongly coupled to upstream modulations in air flow. This could also be true for industrial natural-gas furnaces where furnace dynamics can be influenced by the dynamics of the forced-draft fan, control dampers, or duct geometry. The length of the inlet duct had a significant impact on the pressure and velocity oscillation modes in the combustor. Generally, the velocity lagged the pressure by one-quarter cycle which they note is indicative of standing waves (e.g., as in Rijke tubes).

Acharya et al. [(2013)] analyzed premixed swirl flames subject to helical flow disturbances. The study was motivated by combustion instabilities and combustion noise. Combustion instabilities occur when unsteady heat release couples with one or more of the combustor's acoustic modes. High-amplitude pressure and velocity oscillations can occur. The analysis shows that helical modes can influence the flame “wrinkling” amplitude and heat-release fluctuations differently. The instability parameters exhibit variations in sensitivity to swirl number and other flame parameters. This paper provides a good theoretical analysis of combustion instability.

Sams and Jordan [(1996, 1997)] investigated natural gas burners for firetube indirect heaters. They showed with test data that when the burner nozzle velocity is sufficiently greater than the firetube velocity, the low-frequency rumble decreases. Field data were used to construct relationships between the burner noise level and the gas volume expansion ratio, burner air-to-fuel ratio, mixture flow rate, natural gas orifice velocity, burner area, and the number of burners. They developed a correlation to predict burner noise, and concluded burner rumble will occur when the velocity head ratio of the burner nozzle to combustion chamber is outside the range of 7 to 50.

Iordache and Catalina [(2013)] performed sound-level measurements on two small (770 kW) commercial building heating boilers over the entire boiler operating cycle. Somewhat unexpectedly they found that the highest sound levels were recorded during the ventilation period of the boiler cycle before gas injection rather than at the maximum thermal load period. This indicates that air flow dynamics can be a plausible source of vibration and noise.

Kodis, Webster and Dirks [(2002)] reported an instance where a dirty air heater was the cause for furnace rumble.

Goldring [(2007)] used a computational fluid dynamics (CFD) model to illustrate flame detachment as a function of combustion parameters. The modeling was used to show that the planned burner modifications, which included new staged flame stabilizers, low-NO_x gas lances, and low-NO_x atomizers would produce stable flames over the load range and with a wide range of flue gas recirculation (FGR). Combustion instabilities in industrial furnaces could arise in low-NO_x burners as the combustion limit is approached due to fuel-rich conditions.

Eckstein et al. [(2004)] studied the role of entropy waves in low-frequency oscillations for a diffusion burner.

Seebold [(2005)] presented the theory of formation and mitigation of vibrations, along with personal field experience, in combustion systems ranging from ground flares to steam methane reformers to multi-burner heaters. He gave guidance regarding passive design and operating criteria to reduce the likelihood of rumble. Key to his advice was recognizing the coupling of the fuel-inlet system, the burner, and the combustion chamber, as well as fueling recommendations.

Potential Corrective Measures

There are two recognized approaches to mitigate vibration in industrial boilers or combustion turbines. The equipment can be mechanically altered to reduce or eliminate the vibration. Adaptive or passive control techniques can be used to alter the combustion process to eliminate or reduce vibration.

Eisinger and Sullivan [(2002, 2008)] suggest simple changes to the inlet configuration of the burner to address furnace rumble by slightly altering the operation of the burner relative to the stability line and moving the operation into the no-vibration region.

Berkau et al. [(1990)] use natural gas co-firing to stabilize a deeply staged, low-NO_x coal burner. By introducing natural gas into the primary air line with the coal, the combustion instability is reduced over the load range and better attachment is achieved. By eliminating the fluctuations due to ignition and extinction at the burner front in a deeply staged burner, furnace rumble is eliminated.

Lifshits et al. [(1994, 1995)] eliminated combustion instability in natural-gas industrial burners by more uniformly distributing the natural gas and primary air. This was not a premixed burner. They distribute the gas through small holes along radial slots in the primary zone. Since the gas and air are mixed radially, local oscillations of the flame front occur at different frequencies and therefore do not synchronize, which dampens vibration and resonance problems. This

approach was specifically invented to address furnace rumble due to staging the combustion in low-NO_x burners to reach ultra-low NO_x emissions.

Han [(2008)] used a tunable Helmholtz resonator to dampen oscillations. Both the cavity volume (piston) and throat plate (exchangeable) could be adjusted to alter the resonant frequency. This work provides a nice presentation of calculations of Helmholtz resonance frequency. The Helmholtz resonator was affixed to the side of a cylindrical duct at the end of which was a horn that could be tuned to a range of frequencies. This is an example of adaptive tuning.

Candel [(1992)] employs active control in a pulse combustor. It is shown that in the presence of pressure waves, large-scale motions drive the instability. The paper describes the processes that drive the flame dynamics such as hydrodynamic instability, vortex roll-up, vortex interactions, front and reacting stream pulsations, periodic extinctions and reignitions, and self-acceleration. The paper reviews the basic principles and the initial demonstrations of active instability control of pulse combustors. The application of adaptive control methods is discussed in more detail.

RESULTS FROM RECENT B&W BOILER CASE STUDIES

The configuration of boilers (water or steam filled tubes in cross-flow with air or gas on the shellside) lends itself to a propensity to develop all types of flow-induced vibration. Tube arrays such as generating banks of package boilers are particularly prone to vibration issues and the geometry constraints of the closely spaced tubes and small boiler size make it difficult to design both effective and buildable tube supports. Vortex shedding resonance can likely occur in the generating bank in the low-load or purge-air conditions if proper supports are not implemented. Fluidelastic instability often controls the support design in the high load (high velocity and temperature) conditions. Acoustic resonance (a standing wave in the enclosure that is excited by vortex shedding) can develop if the enclosure is not divided properly to mitigate the risk. Broadband vibration can develop on the upstream and downstream flues if the gas is not uniformly distributed across the flue cross-section or if there is turbulence in the flow. Often, when a vibration problem is observed on a package boiler, there are more than one of these flow-induced vibration mechanisms involved.

One recent case study involved a package boiler that developed tube leaks in the generating bank. Failure analysis of the cracked tubes revealed high cycle fatigue failures, most likely induced by vibration of the tubes during operating conditions. Visual inspection of the generating bank revealed that not all tubes in the generating bank were in contact with the anti-vibration bars, as the tubes had expanded and shifted slightly from their installed positions. The tubes that were not in contact with an anti-vibration bar were susceptible to fluidelastic instability at full boiler load. As a mitigation strategy, additional anti-vibration bars were installed to ensure that each tube maintained contact with an anti-vibration bar and the boiler was returned to normal operation.

Fixes on other boilers are often not this simple or possible. Another case study involved a package boiler that had noticeable deflection of the furnace sidewalls, a rattle on the outlet end of the generating bank (along with several tube leaks), and the buckstay beams that extended across the gas outlet opening were vibrating. Mitigation was implemented in phases and involved reinforcing the buckstay beams, welding flow straightening devices on the portion of the buckstay beams in gas flow, the addition of turning vanes in the gas outlet flue, and the installation of additional anti-vibration bars in the generating bank. The corrections were completed at considerable cost. It was suspected, but not confirmed, that thermoacoustic vibration played a role in the system-wide vibration.

Thermoacoustic

As the industry strives to reduce the capital cost of package boilers through value engineering there is a benefit to strategically reducing the weight of the boilers and reducing the manufacturing cost. This could have the adverse effect of making the boilers more susceptible to flow-induced vibration or thermoacoustic vibration. An improved, more concise approach to eliminating vibration is required to cost effectively decrease capital costs.

A gas-fired package boiler (size FM120) was experiencing vibration issues. In May of 2019, Dr. Jacqueline O'Connor and Dr. Tyler Dare, demonstrated how an acoustic model could identify where the instability had developed in the boiler, and the sensitivity of the system to boundary conditions, geometry, and temperature changes. This type of modeling (COMSOL or ANSYS) identified where a frequency match occurs and assisted with mitigating the problem. In this case, the thermoacoustic vibration could be dampened with a stack damper and the unit's forced draft (FD) fan had sufficient capacity to overcome the additional pressure drop of the stack damper.

PSU used COMSOL to model the acoustic system of the B&W industrial package boiler system. The results of this analysis showed the mode shapes and mode frequencies of this system, which were similar to those measured during earlier field tests. In future work, the team will use Ansys for acoustic analysis. This software would be used to identify the expected mode frequencies and mode shapes for a given system, providing information for sensor placement and inputs to the monitoring software.

Recently, B&W personnel have observed thermoacoustic vibrations first-hand on several industrial boilers. To better understand the problem in a specific case, field measurements were collected from a small natural gas-fired

industrial boiler that was experiencing vibrations of an apparently thermoacoustic origin. Multiple types of instrumentation were used to measure the vibrations including microphones, high-temperature accelerometers, IEPE (Integrated Electronics, PiezoElectric) accelerometers, and dynamic pressure transducers. These sensors were installed throughout the flow path as shown in the plan view in **Figure 2**, beginning at the FD fan, then the air inlet duct, then the furnace (firebox), followed by the generating bank and finally the boiler outlet flue / economizer.

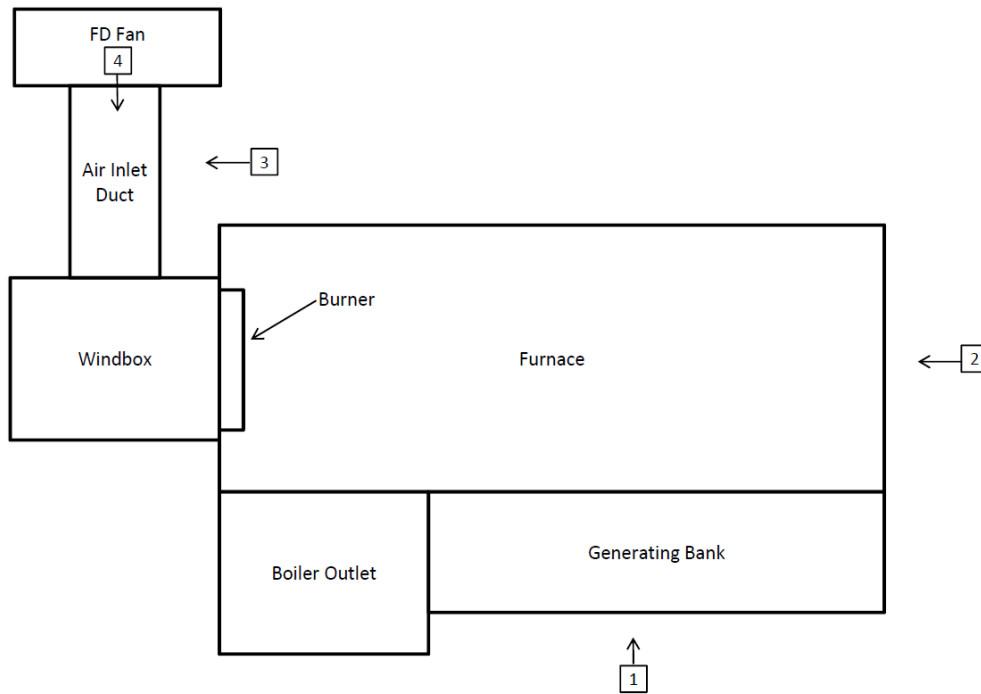

Figure 2. Simplified boiler arrangement and layout of microphones.

During the measurements, the boiler was operated in the load range where significant vibrations were known to occur. Performance parameters of the boiler, such as air mass flowrate and density, were adjusted to determine what impact each of the parameters would have on the boiler pulsation. The only adjustment that appeared to impact the boiler pulsation was increasing or decreasing the firing rate beyond the pulsation range.

The characteristic frequency spectrum measured during the furnace pulsation appeared to be a low-frequency, high-amplitude peak with a sawtooth shape, indicating nonlinearity in the signal. While the amplitude was significantly reduced outside of the pulsation range, the peak frequency remained the same regardless of firing rate.

ANALYSIS OF THE B&W FIELD DATA

As a preliminary step in analyzing the B&W field case data, ORNL and B&W analyzed the basic time-series characteristics of the microphone time series to resolve the general trends they revealed about the vibrations. These analyses included:

- Signal oscillograms — Depiction of the qualitative patterns in the raw signals
- Power spectral density functions — Measure of dominant frequency content
- Temporal irreversibility (T_3) functions — Measure of temporal asymmetry in signal oscillations
- Cross-correlation functions — Measure of linear correlation over finite timescales

Future analyses are planned that will include more sophisticated information-theoretic functions such as transfer entropy to quantify the degree and sense of information flows between measurement locations.

ANALYTICAL RESULTS OF THE FIELD DATA

Signal oscillograms

Figure 3 illustrates the temporal patterns detected by the four acoustic transducers (microphones) at the locations depicted in **Figure 2** for a test in which the boiler unit transitioned from rumble to normal operation and back to rumble after

a ramped-up load change. We examine three 60-s segments of the test, as denoted on the figure, where the burner firing rate was nominally the same, with the only difference being the spontaneous transition out of and back into rumble. Looking at the entire timespan in the figure, the signal envelopes are quite variable, representing overall sound-intensity changes in the boiler unit. Additionally, the long-term drift in the envelope, as seen from 0 to 120 s, is visible and represents a long-term controlled change in firing rate. At about 120 s onward, the firing rate is nominally the same, and changes largely reflect uncontrolled, spontaneous system responses.

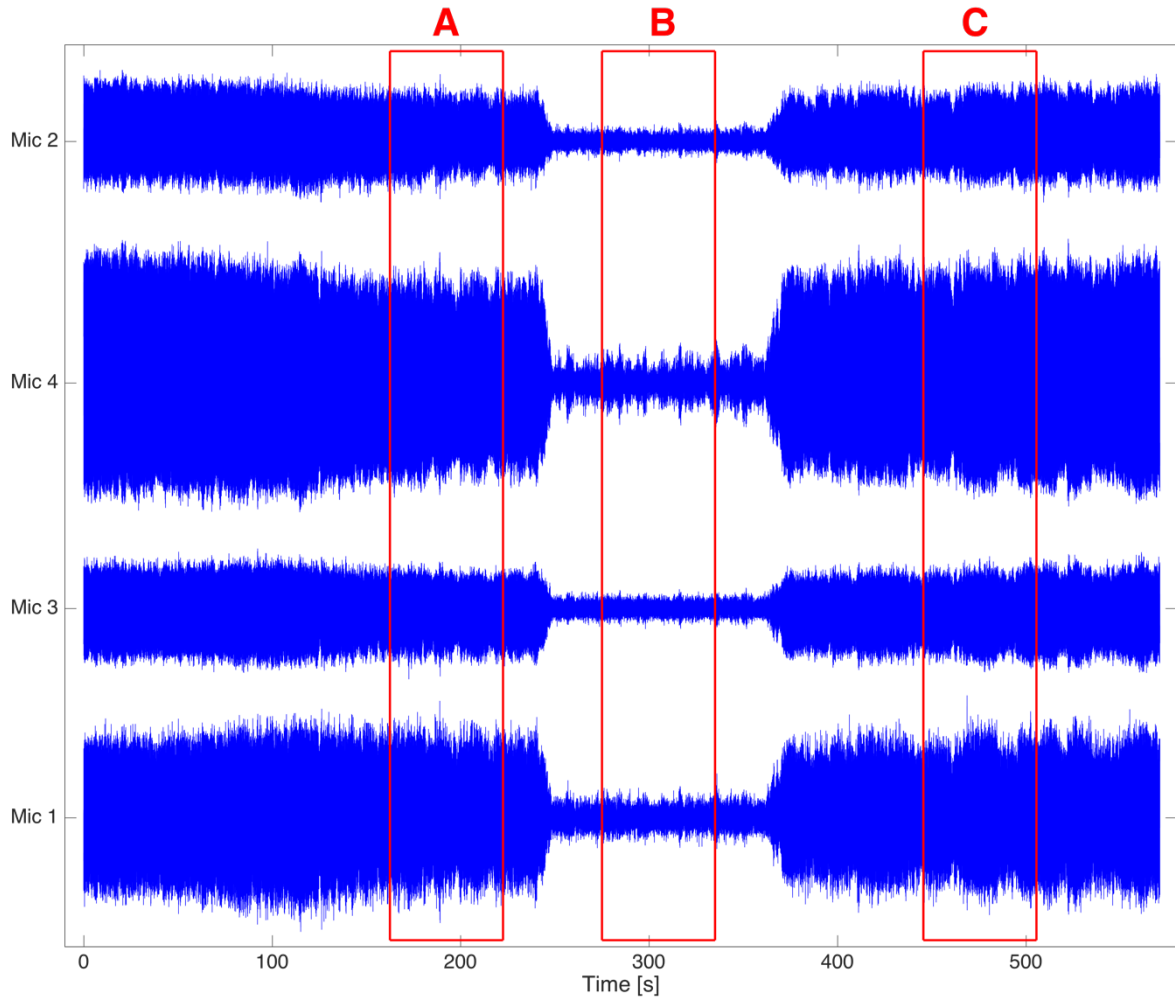

Figure 3. Complete time records for the microphone signals, from top to bottom: firebox (2); FD fan area (4); inlet duct (3); generating bank (1). All the time series are plotted on the same scale. 60-s segments used in later analysis are marked by the red boxes and lettered for reference. Microphone numbers are from Figure 2.

On small timescales, however, distinct differences in the acoustic signal at each location are noted, as depicted in **Figure 4**. In the rumble condition segments, a dominant oscillation of about 10 cycles per second is observed, with higher-frequency content superimposed to varying degrees, depending on measurement location. The signals have very similar characteristics in both rumble segments, even after having spent several minutes in “normal” operation in the interim. The normal-condition signals do contain a discernible large-scale oscillation frequency of about 10 cycles per second, but the higher-frequency signal content is of equal or greater magnitude. The boiler vibrations, as measured by the acoustic sensors, do appear to resonate at a natural system frequency.

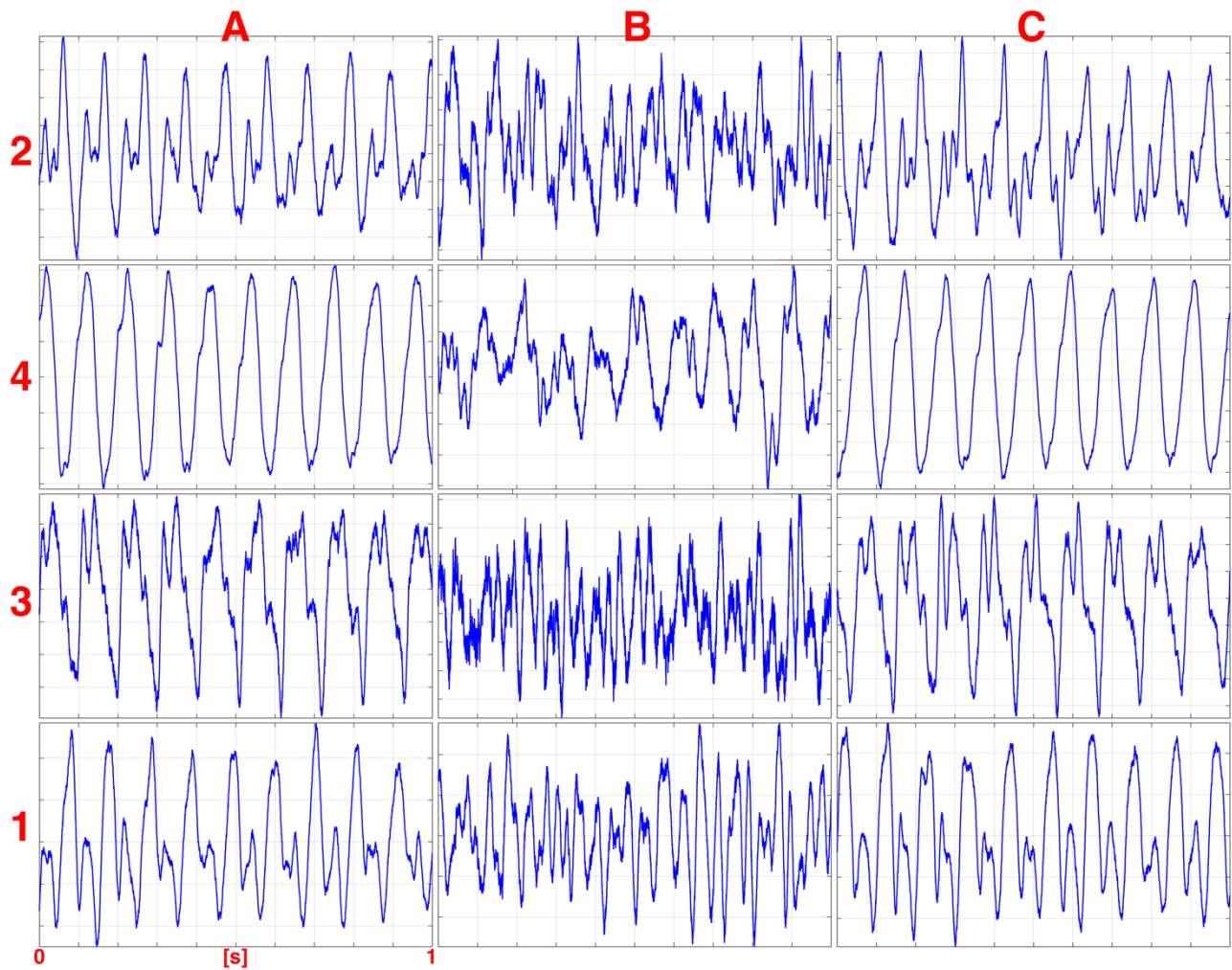

Figure 4. Time-series segments for the microphones at three conditions: rumble (A), normal (B), rumble (C). All segments encompass 1 s of time on the abscissa and are scaled to the segment signal range on the ordinate.

Frequency content

These observations regarding the relative frequency content of the signals is reflected in the power spectral density (PSD) functions, as shown in **Figure 5**. In this figure, the plots' axes are shown on the same scale, with \log_{10} of power on the ordinate and frequency ranging from 0–100 Hz on the abscissa, with the 10 Hz frequency highlighted. For all signals, there is a distinct dominance of the 10 Hz oscillation. In the rumble cases, sharp harmonics of 10 Hz are pronounced, suggestive of the coherence in the signals at the primary harmonic. In the normal case, the harmonics are not significant, but other broadband frequency content, not necessarily at multiples of 10 Hz, is present within 1–2 decades of the 10 Hz content,

suggesting a more complex signal dominated by higher-dimensional causes than observed in the resonance seen in the rumble condition.

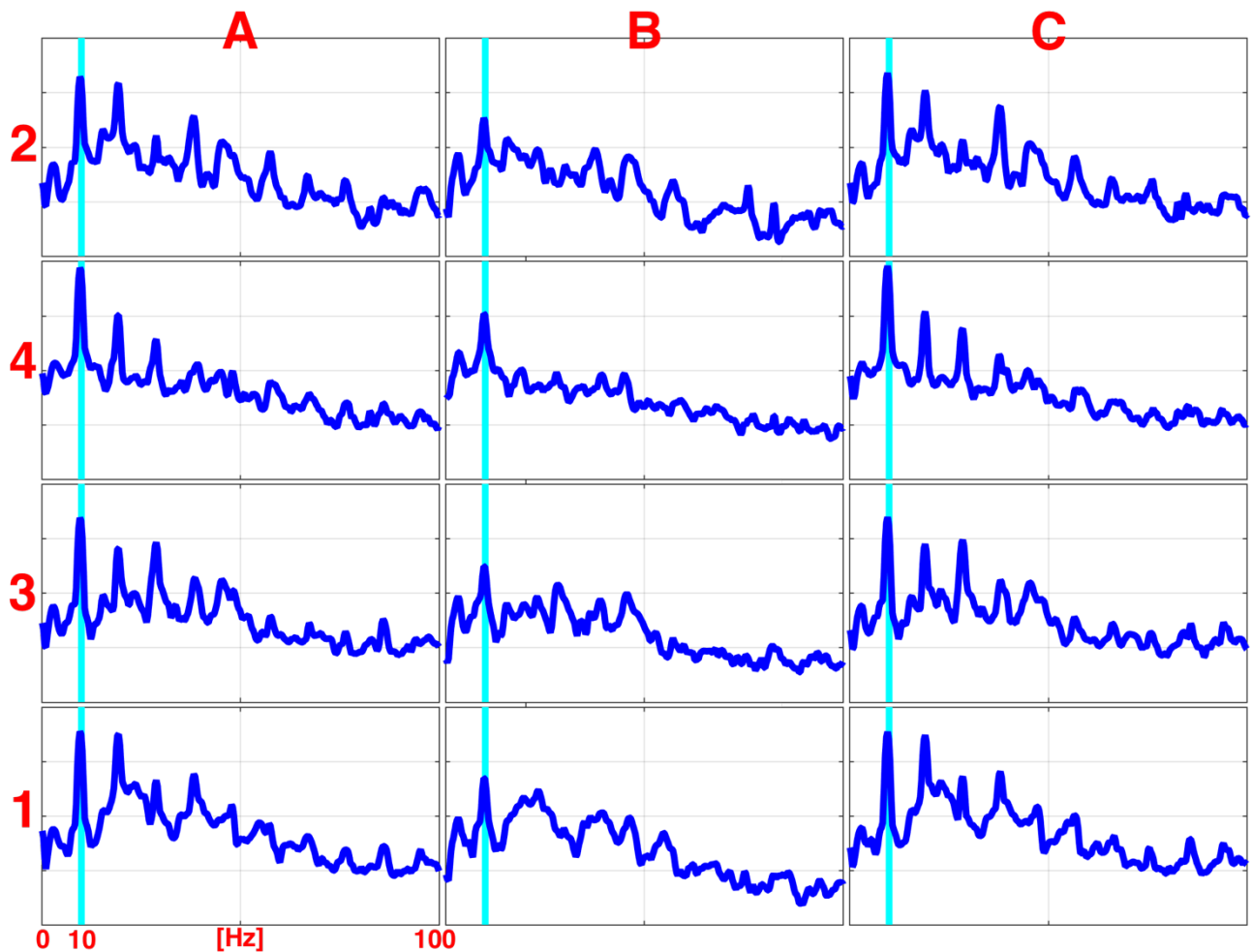

Figure 5. Power spectral density functions for the microphones at three conditions: rumble (A), normal (B), rumble (C). All spectra plotted on same log₁₀ scale, from 0–100 Hz, with 10 Hz highlighted.

A question remains regarding the physical cause behind the 10 Hz natural frequency. This is significant because it does not seem to correspond to the Rijke or Sondhauss modes suggested by Eisinger and Sullivan [(2002, 2008)] as being the primary modes expected to be associated with thermoacoustic vibrations. In the cases they studied, for similar boiler dimensions, the expected frequencies were typically in the range of 30–50 Hz. Thus, there appears to be some other factor involved that is not accounted for by previous work in the literature. One possible explanation for the 10 Hz oscillation is that there could be some type of constructive interference between the FD air fan and the furnace cavity. The fan has a maximum speed of around 1800 RPM, or 30 revolutions per second, and this speed varies depending on the firing rate. In the conditions measured here, the frequency range caused by the blade passages is thought to be around 180 Hz. To some extent, the fan oscillation frequency, coupled to the overall volume of the supply system and firebox, could explain the observations, and we are investigating to within the limits of available design and operating data to verify this assumption.

Another possibility is that the expected relationship between the pre- and post-burner resonance zones (i.e., between the air inlet and furnace cavities) that leads to the dominant frequency oscillations may not apply in this particular case. More specifically, it may be that the Rijke and Sondhauss modes are not dominant here, but instead there is another set of acoustic modes that are interacting with the heat release from the burner to drive a lower frequency resonance. This might occur if the characteristic wavelength in the air inlet is actually different than suggested by Eisinger and Sullivan, resulting in the creation of a lower-frequency beating between the air inlet and furnace zones. As with the fan coupling, we are also investigating these other modes as possible root causes.

Time irreversibility

One of the more sophisticated analytical tools we are using to help understand the 10 Hz oscillations is time irreversibility. As is slightly visible in **Figure 4**, the large-amplitude acoustic waveforms were sawtooth shaped. For instance, for the fan-area transducer (microphone 4), the waveform has a slow rise to the cycle maximum and then a rapid fall to the cycle minimum; the opposite is seen for the air-duct transducer (microphone 3). Time asymmetry is important because Gaussian sources, or static transforms thereof, are temporally reversible, meaning that there is a statistical difference in time-sensitive metrics depending on whether the signal is examined in the forward or reverse sense. A metric capturing this difference, the T_3 function, is displayed in **Figure 6**. Each plot ordinate contains the same scale — the T_3 metric is normalized — and the abscissa displays timescales from 0–0.2 s, much like with correlation functions. This time range captures roughly two cycles of the fundamental oscillation of the microphone signals. We note that opposite trending patterns occur in microphones 3 and 4. Additionally, the normal, non-rumble mode T_3 metrics are close to 0, suggesting a different cause than in the rumble conditions. Irreversibility is a hallmark of nonlinearity, and in many combustion systems, flame-oscillations are known to be temporally asymmetric. Thus, the observation of pronounced irreversibility suggests that the flame is a key component of the vibrations, and thus the root cause is thermoacoustic vs. flow-based resonance.

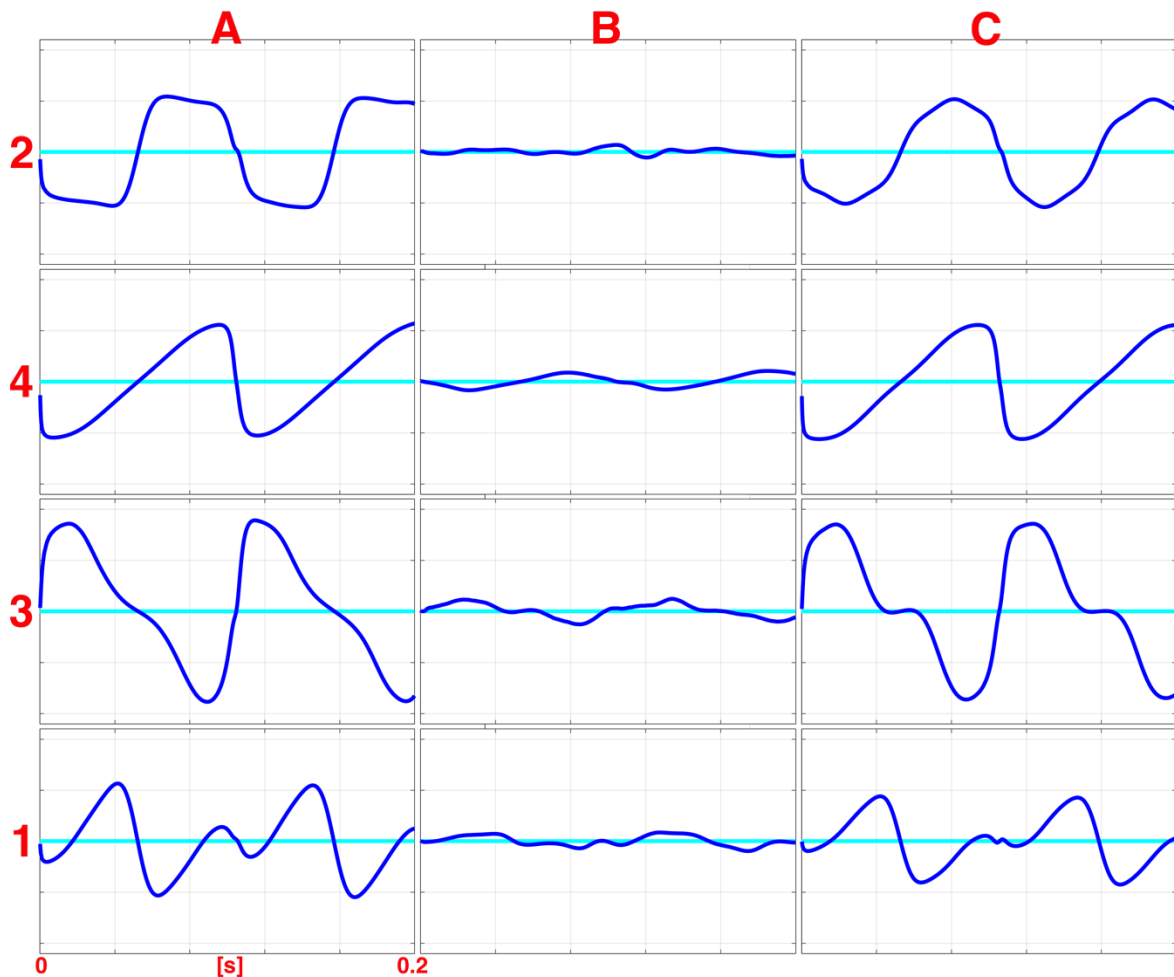

Figure 6. T_3 (irreversibility) functions for the microphones at three conditions: rumble (A), normal (B), rumble (C). All functions plotted on same scale, from 0–0.2 s lag, with $T_3=0$ highlighted.

Correlation analysis

In thermoacoustic oscillations, pressure/sound waves are expected to propagate outward from the flame. In the field tests, we did not have the opportunity to measure this directly. However, with spatially separated microphone measurements recorded simultaneously, the cross-correlation in the signals can provide some insight. In the analysis below, we will use the air inlet duct microphone as the reference signal location, as it was closest to the base of the flame.

We use two metrics to compare the temporal correlation between the FD fan, the firebox, and the generating bank signals referenced to the inlet duct signal. The first metric is the *cross-correlation function*, which quantifies the linear correlation, or covariance, of two signals over a range of timescales. Cross-correlation is frequently employed in flow systems to measure timescales for spatial propagation of waves or flows. The second metric is the *bivariate mutual information function*, which quantifies the cross-mutual information of two signals over a range of timescales. As such, the bivariate mutual information may be thought of as a generic, not necessarily linear, measure of correlation. In both types of correlation, comparison of signal correlation is typically referenced as signal Y with respect to (wrt) signal X. Positive correlation of Y wrt X means that Y lags or follows X at the given time delay. The mutual information function always has positive values, whereas cross-correlation values may have negative values, for anticorrelation. In our implementation, cross-correlation is normalized by the covariance of X and Y, so its values range from -1 to +1; the bivariate mutual information is positive, in units of bits.

The cross-correlation functions for unique pairs of microphone signals are portrayed in **Figure 7**. A few general features of the cross-correlation functions may be noted. First, during rumble, there is stronger correlation compared with non-rumble between pairs of microphone signals, owing to the stronger coherence of each signal (even though this difference is not as apparent as with the T_3). Second, certain relationships are apparent in the locations of the correlation peaks. For instance, signal 1 lags signal 2 (top-most row), meaning the oscillation waveform happens in signal 2 before 1 (or at the firebox back wall before the generating bank), and signals 3 (inlet duct) and 4 (fan area) precede 2 (firebox back wall), suggesting a propagation of information from the fan or burner area downstream. However, because of the long-term cyclic persistence observed in the correlation functions, it is difficult to produce an exact mapping of information (pressure) propagation.

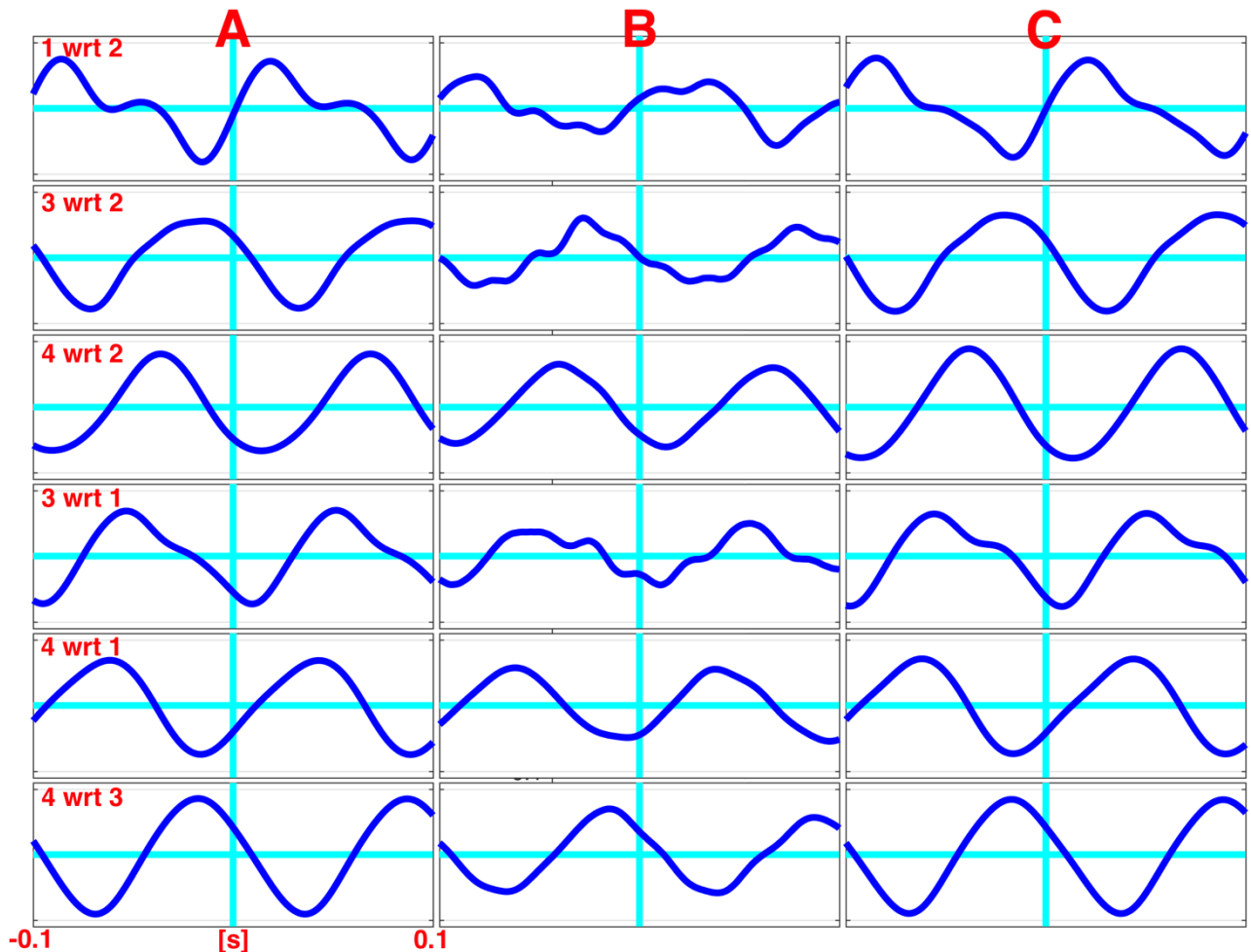

Figure 7. Cross-correlation functions for the microphones at three conditions: rumble (A), normal (B), rumble (C). All functions plotted on same scale, from -0.1 – $+0.1$ s lag, with 0-axes highlighted. Positive correlation of Y wrt X means that Y lags or follows X at the given time delay.

A comparison of the mutual information with cross-correlation for select microphone signal pairs is seen in **Figure 8**. Many of the significant timescales match between the two correlation metrics (remembering that the anti-correlation troughs in cross-correlation appear as peaks in the mutual information, which is always > 0).

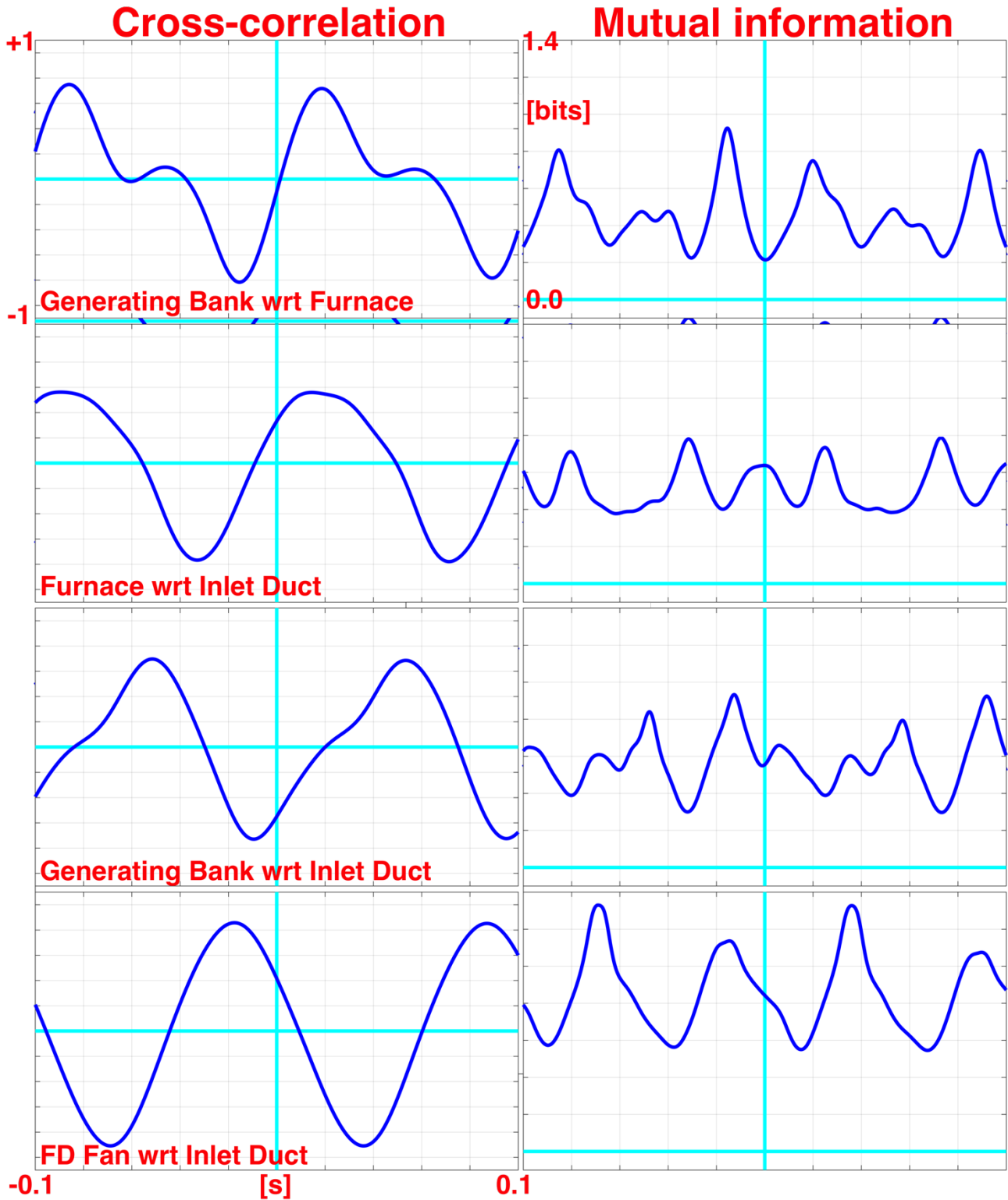

Figure 8. Comparison of cross-correlation and mutual information for select microphone signal pairs.

In interpreting these timescales, we first must understand the conditions in the gas flow path, especially focusing on the speed of sound. Correlation timescales must be longer than the sound travel time between the pair of sensors, or else they are

spurious. Based on process conditions and physical distances between sensors, estimates of relative conditions are shown in Table 1. The speed of sound ranged from ~355 to ~775 m/s depending on the chamber — the hot gases in the firebox have the highest speed of sound, with the generating bank the next highest, and the inlet duct and FD fan area the lowest. In calculating the speed of sound in a chamber, the gas composition and temperature were assumed to be homogeneous, and travel times were summed between chambers with different compositions.

Table 1. Correlation timescales between microphone pairs.

Microphones	Distance [m]	Sound time [ms]	Correlation time [ms]	Sense
Generating Bank wrt Firebox	4	6	20	GB lags Firebox
Generating Bank wrt Inlet Duct	16	27	55	GB lags Inlet Duct
Firebox wrt Inlet Duct	13	21	60	Firebox lags Inlet Duct
FD Fan wrt Inlet Duct	2.8	8	18	Inlet Duct lags Fan

The correlation times generally confirm a propagation of information from the inlet duct area, specifically near the FD fan, downstream. The thermoacoustic instability seems to interact with and amplify the ~10 Hz natural frequency during rumble. Work is ongoing to define the natural frequency as well as identify means to disrupt its coherence.

In future work, we plan to continue analysis with general, information-theoretic measures such as transfer entropy to refine the sense of the information flows between sensors. The first pass of analysis suggests that information flows from the base of the flame area outward, which is consistent with a thermoacoustic mechanism, during rumble, given the strong time irreversibility. Further, there is no dominant flow-induced vibration effect propagating upstream from the generating bank.

JOHN ZINK CASE STUDIES

Thermoacoustic vibration has long been a challenge in industrial combustion applications. John Zink Company has encountered many vibration challenges over the last 50+ years and developed design strategies to minimize the probability of vibration as well as mitigation techniques.

Unexpected thermoacoustic vibration remains an ongoing challenge for a small percentage of installations. One illustrative example of the engineering challenge of thermoacoustic vibration is “The Twin Paradox.” An infrequent, confounding challenge within industrial packaged boiler applications are cases of differing behavior between identical systems. One unit will have either no or very minor issues with vibration, while an identical unit will have significant vibration. Often an effort will be initiated (typically driven by the equipment owners) to audit the systems and identify equipment differences with the thought there must be a physical difference that explains the differing performance. In some cases, this effort has led to resolution. One anecdote was a system with identical burner/furnace equipment but forced-draft fans that were mirrored (left-side on one unit and right-side on another). Vibration was resolved in this case by mirroring the burner design to change the direction of swirl and fuel injection (likely to match a co-spin direction of the incoming combustion air flow). But for most cases of identical equipment with non-identical performance, the exercise of “find the difference” is an unsuccessful endeavor. Rather, the strategy to resolve vibration requires a novel change to the burner or system resulting in different equipment configurations between units. Thus, while vibration challenges can be resolved, the underlying source remains a mystery.

Prior to the last 25 years, methods to resolve vibration focused heavily on trial-and-error approaches while leveraging lessons of the past to generally favorable but occasionally mixed results. During this era, general techniques were identified to resolve vibration including:

- For “panting” issues (<10hz lower frequency pulsations), closing/throttling the stack damper generally resolved most issues encountered.
- For “rumble” issues (>30hz), changes to the burner tips or swirl pattern generally could resolve most issues.
- Avoid injecting fuel in a highly uniform/symmetrical pattern

Burners of this era were typically highly configurable (pre-spin louvers, multiple air-zones, rotatable gas injectors, etc.) allowing service personnel flexibility to avoid vibration through burner settings.

Over the last 20 years, burner technologies advanced to reduce NO_x emissions. Design techniques such as heavy fuel-staging and lean premix are now utilized in burner designs. Byproducts of these changes are:

1. Burners have become less configurable. Due to specific mixing and flow-field requirements to meet NO_x emissions, burner configurability has become limited.
2. Thermoacoustic vibration is more likely. Modern design techniques to reduce peak flame temperature also result in more narrow bands of flammability. Additionally, premix techniques can lead to high temperature uniformity increasing the risk of rumble.

In recent years, analysis methods to identify and resolve thermoacoustic vibration have progressed while measurement devices, such as high-speed pressure transducers, have become more readily available. The core of these updated methods is the capture, data-processing, and analysis of high-speed pressure pulsations within the system.

Whelan [Whelan (2019)] suggested a simplified analysis of this data is sufficient to identify and resolve most vibration challenges when coupled with design best practices and practical mitigation techniques. It is suggested that while identifying the exact driving mechanisms and transfer functions of the system would be highly valuable, it is remarkably challenging on real systems. Rather, high-speed vibration data can be utilized to identify target areas that will provide the highest level of success where well-known mitigation techniques can be deployed.

The simplistic strategy recommended is to collect data at a variety of operating conditions and system locations, then convert raw time-series data to frequency bands using Fourier analysis or other methods and compare datasets. Datasets generally fall into two categories:

1. Asynchronous: For systems that exhibit vibration with a high degree of asynchronous and chaotic behavior in the pressure signal, it is recommended to focus on changes to the burner. This analysis assumes the source of pressure pulsations is combustion and the pressure signal is mimicking the chaotic behavior of combustion.
2. Synchronous: For systems that exhibit vibration with a high amount of synchronous behavior (sharp high-amplitude frequency peaks), it is recommended to focus on changes to the system. This analysis assumes the system is entering resonance. Using the system geometry, the natural frequencies of the system can be computed and compared to the peak frequency from the data. This analysis method typically provides a strong indication of the acoustic driver and resonance mechanism (e.g., standing wave, Helmholtz, etc.).

Thus, a mitigation technique can be deployed to target changes to system geometry or system drivers.

Two (2) examples of case studies are presented. Note that project summary details, datasets, and data analysis have been significantly simplified for clarity.

Asynchronous Example:

An international industrial combustion unit experienced severe vibration following the retrofit of low-NO_x burner technology. After considerable effort to avoid vibration through equipment tuning, vibration data was collected, and is shown in **Figure 9**.

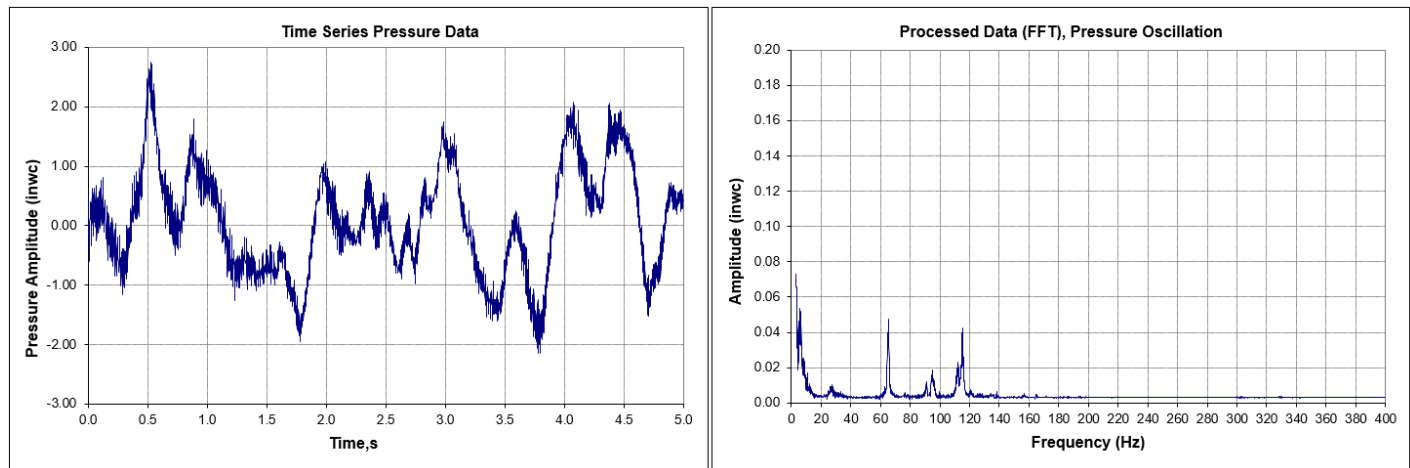

Figure 9: Vibration data collected after the retrofit of low-NO_x burner technology.

The dataset was taken in the combustion furnace. Time series data has been normalized. Note processed frequency band data identifies peak frequencies at 65 and 115Hz. However, the amplitude of these peak frequencies is significantly less than the amplitude of the time series pressure fluctuations. This indicates pressure pulsations are largely asynchronous.

This vibration example was resolved through modifications to the burner's fuel injection pattern. It was found there was novelty in the burner configuration, and the working theory for the source of pressure pulsations was a poorly anchored combustion flame where fuel and air burned in an unsteady flow-field in the furnace chamber.

Note, if the frequency band data was the sole source of analysis, this could lead to unsuccessful mitigation paths which focused on sources of natural frequencies in the system that matched either 65 or 115Hz.

Synchronous Example:

A new ultra-low NO_x boiler system experienced severe vibration during commissioning. Following tuning efforts, vibration data was collected and is shown in **Figure 10**.

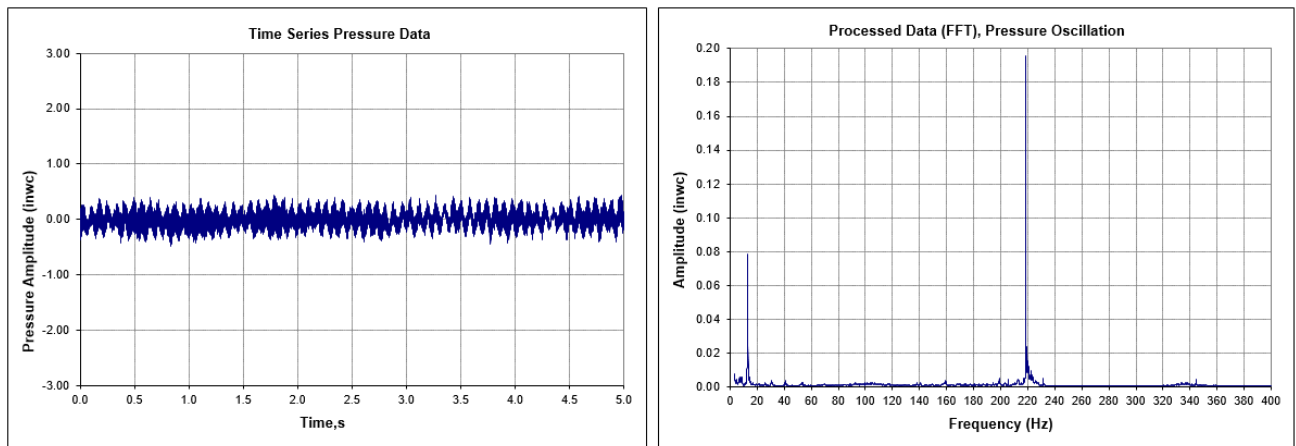

Figure 10: Vibration data collected after tuning efforts on a new ultra-low NO_x boiler system.

The dataset was taken in the combustion furnace. Time series data has been normalized. The frequency data identified two very sharp frequency peaks at 13 and 220 Hz. The scale of the frequency peaks was of similar amplitude to pressure pulsations observed in the time series data. This indicates strong resonant and synchronous behavior.

For this case, the natural frequencies in the system were identified. It was found that a standing wave natural frequency corresponding to a length scale of the system was the most likely candidate for the 220 Hz frequency peak. Modifications were executed to disrupt this length scale within the system which successfully resolved vibration.

Though analysis methods exist to resolve thermoacoustic vibration, in many cases the true driving mechanisms are not well understood. Predictive methods to better identify potential vibration modes and probability that can be utilized prior to equipment operation would be highly useful. Further research and the advancement of system simulation techniques are needed.

PENN STATE CASE STUDY

Several methods for predicting and identifying the source of oscillations in boiler systems have been attempted in partnership with researchers at The Pennsylvania State University. A package boiler system exhibiting low-frequency oscillations was both tested and simulated.

As described in Dare [(2019)], preliminary testing had shown that the package boiler exhibited pulsations at approximately 9 Hz when the firing rate of the boiler was between 50% and 70% capacity. A series of measurements was conducted to identify the nature of the pulsation.

A microphone near the fresh air intake was monitored while the firing rate was varied in and out of the range where pulsation was occurring. Without pulsation, a 9 Hz tone was measured, which was understood to be an indication of an acoustic resonance within the system. At the onset of pulsation, the tone became approximately 15–20 dB louder and harmonics appeared at multiples of the fundamental frequency. The sudden increase in level and appearance of harmonics were taken to be indications that a nonlinear acoustic phenomenon was occurring, likely a thermoacoustic instability.

Measurements made with dynamic pressure sensors supported the thermoacoustic instability hypothesis. Two pressure sensors similar to a sound intensity probe were used to estimate the acoustic particle velocity of the acoustic waves with and without pulsation occurring. Without pulsation, the acoustic particle velocity was estimated to be 0.24 times the air flow velocity. With pulsation, the acoustic particle velocity increased to 0.33 times the air flow velocity.

Accelerometers placed on the exterior of various parts of the system were used to estimate the acoustic mode shape of the 9 Hz mode. It was concluded that a low-order longitudinal duct mode was present, but the exact number of acoustic nodes could not be determined. It appeared that acoustic energy was generated in the furnace and propagated up the outlet flue and through the economizer.

The goal of the companion simulation analysis was two-fold. First, we wanted to identify any pressure anti-nodes inside the boiler, indicating the possibility of thermoacoustic instability in the system. Second, we performed an initial sensitivity study to understand the impact of temperature and boundary conditions on the resonant frequency of and mode shape in the system. Simulations were completed in Comsol Multiphysics in a simplified geometry. The complex geometry of the package boiler system and its supporting components were converted to a linear model that maintained the area changes from

one component to the next, but not the bends in the system. In this way, a system with several turns and layers was converted to one long system, as shown in **Figure 11**. At the frequencies of interest (on the order of 10 Hz), these more complex geometric features would not significantly impact the mode shape, and so initial studies only considered the linear model. It was assumed that the cross-section of each unit was a square with the same cross-sectional area of the actual component. Further, if the component cross-sectional area varied along its length, an average area was used in the model of the system. The assumption of one-dimensional acoustics is justified by the length of the system relative to every other dimension, as well as the known modal frequency. As the system is so much longer than it is wide or deep in any one part of the system, then the dominant mode will be longitudinal, or one-dimensional, along the length of the system.

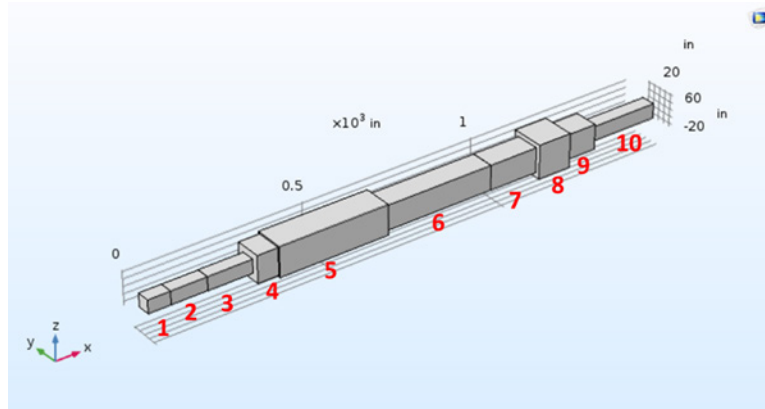

Figure 11. One-dimensional Comsol model of the package boiler system.

The baseline case was defined with the following temperature and boundary conditions. Temperatures were estimated using half the adiabatic flame temperature of methane for the first furnace leg to account for mixing with ambient air and half of that temperature downstream of the first furnace leg to account for cooling.

- Temperature conditions:
 - 1 – 4: 300 K (80° F)
 - 5: 1000 K (1340° F)
 - 6 – 10: 500 K (440° F)
- Boundary conditions:
 - Pressure release inlet
 - Pressure release outlet
 - All other surfaces hard wall

Figure 12 shows the instantaneous pressure fluctuation mode shape at these conditions. This mode represents the second eigenmode, or resonant mode, of the system. The first eigenmode has a frequency of 3.3 Hz, too low for the instability measured in the system. Note that the pressure fluctuation at the inlet and outlet of the system is zero as a result of the pressure release boundary conditions. Within the combustor, two anti-nodes occur, as would be expected in a first longitudinal mode: one in the first furnace section and one in the economizer. The pressure anti-node in the first furnace leg aligns with the flame location, indicating the potential for thermoacoustic coupling. Additionally, the frequency of this mode is 9.3 Hz, which is on the order of the measured frequency in the system during instability. This baseline case strongly suggests that the oscillations measured in this system were the result of thermoacoustic oscillations due to coupling in the first furnace section.

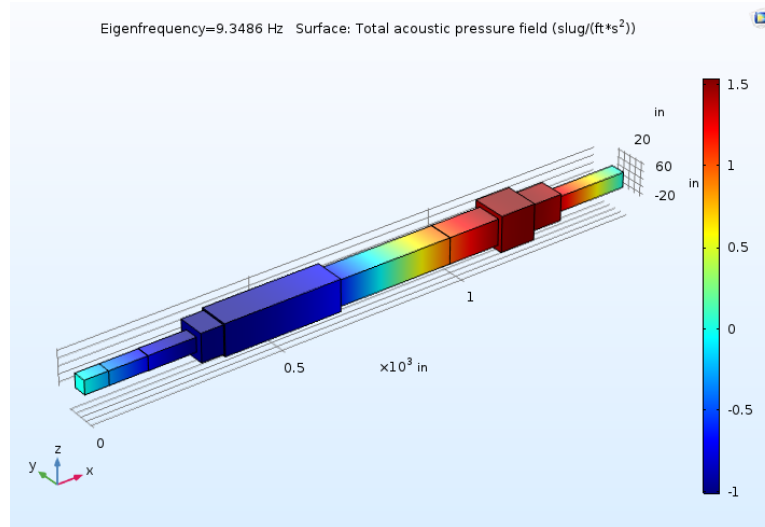

Figure 12. Instantaneous acoustic mode at baseline conditions.

The resources at Penn State have been invaluable in helping B&W solve more complex acoustics problems. In the case of the FM120 industrial boiler mentioned above, they were able to help B&W complete a detailed test and analysis to help us quickly identify and resolve the issue.

Systems may exhibit warning signs of potential thermoacoustic instability before they enter an unstable state. Such warning signs might include increasing coherence of oscillations in the pressure signal or higher amplitude oscillations in frequency bands of interest. Many early detection algorithms have been tested for gas turbine applications [Sewell and Sobieski (2005); Goy et al. (2005)], where oscillation frequencies occur in the 100s of Hertz. However, relatively little work has considered identification at lower frequencies, as would be seen in a boiler system, and there are several potential advantages to monitoring for signals with low frequencies. By analyzing operating conditions, system parameters, and existing monitoring sensors, an algorithm can be developed.

GOAL

The remainder of this paper will describe an improved method to either predict the potential of thermoacoustic vibration or diagnose the root cause on an existing heater or furnace. An approach is suggested to address thermoacoustic vibration on commercial natural gas package boilers using a combination of acoustic finite element analysis (FEA) modeling and field data. Experience and field data from past episodes of thermoacoustic vibration is integrated into the acoustic FEA modeling. The research team comprises a unique combination of very experienced industry, university and national laboratory members to address this very important pervasive issue.

OBJECTIVES

To implement a thermoacoustic model of package boilers and develop a vibration monitoring tool that is informed by the modeling and can be implemented in a number of different combustion systems.

LIMITATIONS AND SCOPE

The experimental data included in this study was generated without the benefit of controlled experiments on industrial-scale units. Instead, field measurements were collected from a commercial boiler to illustrate an actual case of industrial relevance, its quantitative characteristics, and how it compared with expected patterns. Future experimental field tests are being planned for this and other units that will provide additional data to improve basic understanding of the problem and support improved designs and/or operating strategies. We specifically do not address the problem of flow-induced vibration here, which can also occur in industrial furnaces and boilers.

The analysis is limited to existing data from past field tests on industrial package boilers. No new field testing was conducted to support the approach and results presented. Plans are to acquire validation data sets from industrial boilers and heaters in the future.

APPROACH

Thermoacoustic instabilities have been shown to create concerning vibration issues on single-burner natural gas package boilers as well as on multi-burner gas/oil fired utility and industrial boilers and heaters. Thermoacoustic vibration arises from the coupling between the acoustics of the burner and associated combustion cavity and heat release rate oscillations in the flame. The mode of acoustic oscillation is driven by the shape of the cavity and burner, as well as the boundary conditions set by multiple elements in the system.

Pulsations and vibrations downstream of the combustion cavity propagating back to the combustion cavity

In complex systems like boilers and heaters, there are a number of different coupling mechanisms that link the acoustic oscillations in the system to the flame heat release rate oscillations. First, fluid mechanic oscillations in the flow in and around the burner are a common coupling mechanism.

Flame instabilities and pulsations stemming from upstream pulsations

Second, thermoacoustic instability has been shown to be driven by periodic ignition-extinction of the flame, driven by recirculating combustion gases.

Maldistribution of recirculating combustion gases back to the ignition-extinction front of the flame either from within the combustion cavity or externally via flue gas recirculation for NO_x control

Third, resonance of the flame with the combustion cavity walls.

Equivalence-ratio coupling could be a factor in these systems [Seebold (2005)]. Control of the instability can be achieved through a combination of changes to the flame and the overall burner system. For example, fuel staging, or the redistribution of fuel amongst the various fuel-injection manifolds in a single burner, can significantly reduce oscillation amplitude. Often the vibration cannot be eliminated by only addressing one of the potential root causes.

Thermoacoustic vibration problems are pervasive in industry not only in package boilers, but in gas-fired heaters as well. As the burner design is pushed to lower and lower excess air levels (more sub-stoichiometric) in the interest of reducing NO_x, the combustion is pushed to the stability limit where ignition/extinction events induce pulsing in the combustion and associated thermoacoustic vibration. If the combustion frequency occurs at the resonance frequency of the combustion chamber, severe furnace rumble could occur potentially causing damage to the structural integrity of the boiler. To complicate the situation even more, the forcing function of the thermoacoustic vibration could stem from or be compounded by upstream or downstream flow-induced vibration. In addition, challenges such as maintaining a small equipment footprint and reducing overall weight of a unit introduces other factors such as abrupt flow transitions and less mass for damping. Due to these complexities, it is often extremely difficult to diagnose the root cause(s) of vibration in package boilers. This causes potentially destructive low-frequency furnace rumble. Often with changes in the combustion conditions at the burner the vibrations can be lessened, but sometimes this alone is insufficient and additional costly and complex solutions may be required.

Much work has already been done to understand thermoacoustic vibration, how to prevent such instabilities from occurring in the first place, and cost-effectively diagnosing and correcting a problem on existing units. However, the tools to apply this knowledge to various and unique boiler configurations are lacking. A troubleshooting tool would especially be of great benefit to the industry, as thermoacoustic instabilities are complex and may be difficult to predict accurately even with the most advanced tools. Tools currently exist with a wide range of fidelity, where high-fidelity tools provide high levels of insight at significant costs in terms of computational power and time. For example, Helmholtz acoustic solvers like Comsol or Ansys could be used to identify the resonant acoustic mode shapes in a system. The system could be solved over a range of operating conditions (system temperatures and flow rates), as well as a range of boundary conditions (damper settings, etc.). Cases where mode shapes had anti-nodes in the flame-stabilization region could be at risk of developing thermoacoustic combustion instabilities. The next level of fidelity would be to couple an acoustic solver with a flame-response model, as in a network acoustic mode, such that the acoustic modes are solved for with a source term from the flame. These types of models have been implemented in gas turbine combustion systems with high levels of success in predicting instability mode shapes and frequencies in relatively complex geometries [Sattelmayer and Polifke (2003)]. Finally, high-fidelity computational fluid dynamics could be used, and although methods for instability prediction are improving [Poinsot (2018)], the computational cost is still significant due to the coupling of acoustic, fluid, and chemistry solvers required for these systems.

The team has identified the following approach to develop an improved method for predicting or diagnosing thermoacoustic vibration. The collaborative contributions of the team members for developing thermoacoustic vibration tools are shown in **Figure 13**. Unique to this approach is focusing the effort to understand the coupling of the burner with the combustion cavity, and to identify options for modifying either to address the issue. The intended process follows:

1. Identify test system for development that has available drawings and operating conditions to implement into Ansys as well as acoustic data for testing and developing the monitoring software.
2. Use Ansys acoustic modeling capability to model the acoustic mode shape and frequencies associated with the target system. Use this model as inputs to the monitoring software, and to gain insight into sensor placement for future monitoring.
3. Using data and models from sites with known thermoacoustic instability concerns, parameters relevant to instability will be identified.
4. Develop a method to provide real-time output of the instability condition in a form that is interpretable to plant operators. For example,
 - a. Green light: No instability detected.
 - b. Yellow light: Instability possible under current conditions.
 - c. Red light: Unstable operation detected.
5. Integrate code into custom module to an open-source code such as the U.S. Department of Energy’s IDAES Software Package.
6. Integrate the custom module as part of an advanced package boiler or heater control system and system optimizer. The advanced control system could include condition assessment and predictive maintenance add-ons as part of on-going monitoring of the unit performance.

The product of the development effort would be example acoustic models from Ansys and modal analysis results.

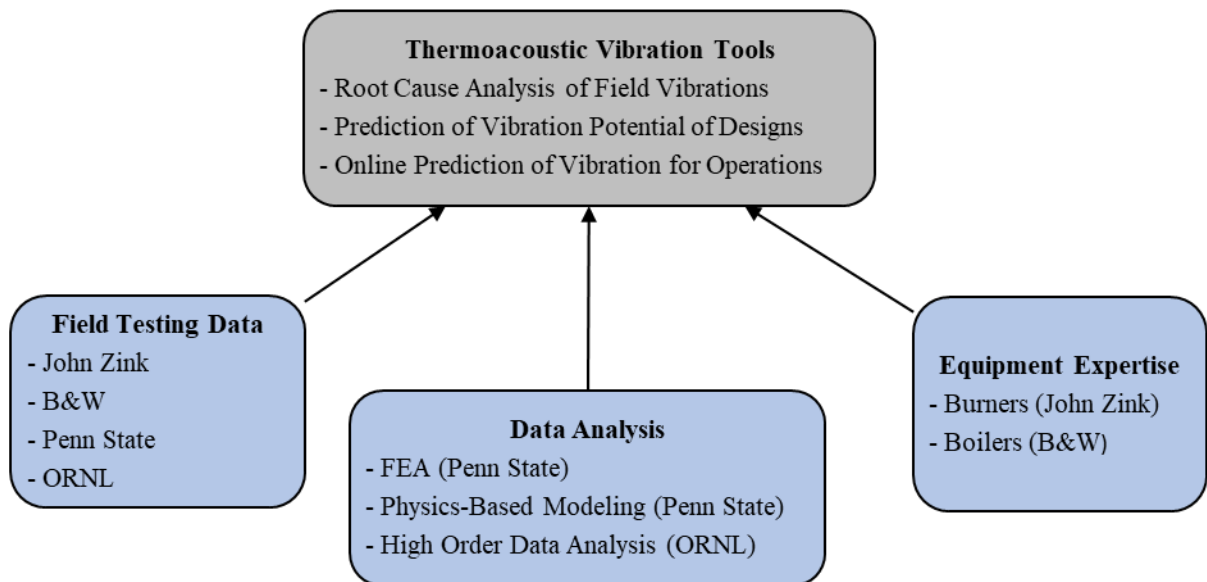

Figure 13: Team members and their collaborative contributions for developing thermoacoustic vibration tools.

CONCLUSIONS

Several case studies have been presented to demonstrate that industrial gas-fired boilers, furnaces, and heaters occasionally develop thermoacoustic vibration. These thermoacoustic vibrations are complex and are often difficult to predict, diagnose, and mitigate. Thermoacoustic vibration is more difficult to predict than flow-induced vibration due to the complicated resonance coupling of the burner and combustion cavity. Sometimes even seemingly identical boilers do not exhibit the same response and one unit will develop a thermoacoustic vibration while the other unit does not, due to the many factors that contribute the coupling behavior of the vibration. Diagnosing a thermoacoustic resonance can also be challenging, especially if more than one vibration mechanism is involved, as is often the case. Mitigation of thermoacoustic vibration can vary greatly in cost and complexity, but may include operational changes, changes to burner tips or swirl pattern, structural reinforcement, addition or throttling of a stack damper, and dimensional changes of a cavity.

An improved method to predict the potential of thermoacoustic vibration or diagnose the root cause on an existing heater or boiler is desired. A collaborative approach has been presented in this paper, to develop the tools to address thermoacoustic vibration on commercial natural gas package boilers using a combination of acoustic finite element analysis (FEA) modeling and field data. Field testing data and models from existing units with known thermoacoustic vibration would be used to identify parameters relevant to instability. A method to provide real-time output to plant operators would be developed, and then the code would be integrated in an open-source platform. Ultimately, an advanced package boiler or heater control system would be developed to include condition assessment and predictive maintenance capabilities to both mitigate thermoacoustic vibration and provide on-going performance monitoring.

ABBREVIATIONS

CFD	Computational Fluid Dynamics
FEA	Finite Element Analysis
FGR	Flue Gas Recirculation
IEPE	Integrated Electronics, PiezoElectric
PSD	Power Spectral Density

SYMBOLS

L	= Characteristic acoustic length of furnace cavity [m]
l_1	= Characteristic acoustic length of burner air inlet [m]
T_1	= Furnace (post-burner) temperature [K]
T_2	= Burner air inlet temperature [K]
T_3	= Temporal Irreversibility Function
$\xi = (L-l_1)/l_1$	= Characteristic geometric parameter for Rijke and Sondhauss resonance modes [-]

REFERENCES

- Acharya V.S., Shin D. -H., Lieuwen T.** (2013). Premixed flames excited by helical disturbances: Flame wrinkling and heat release oscillations. *Journal of Propulsion and Power* **29**(6): 1282–1291. [doi:10.2514/1.B34883](https://doi.org/10.2514/1.B34883).
- Balasubramanian K., Sujith R.I.** (2008). Thermoacoustic instability in a Rijke tube: Non-normality and nonlinearity. *Physics of Fluids* **20**: 044103. [doi:10.1063/1.2895634](https://doi.org/10.1063/1.2895634).
- Berkau E., Breen B., Gabrielson J.E., Winberg S.** (1990). Low NOx burner operations with natural gas cofiring. U.S. Patent 4960059.
- Burney G., Gallagher M., Landseidel M., Storm R.** (1995). Performance optimization of a boiler equipped with low NOx burners. *Power-Gen '95*, Anaheim, CA USA. http://www.stormeng.com/pdf/Power-Gen_1995.pdf.
- Candel S.M.** (1992). Combustion instabilities coupled by pressure waves and their active control. *Proceedings of The Combustion Institute* **24**(1): 1277–1296. [doi:10.1016/S0082-0784\(06\)80150-5](https://doi.org/10.1016/S0082-0784(06)80150-5).
- Chanaud R.C.** (1994). Effects of geometry on the resonance frequency of Helmholtz resonators. *Journal of Sound and Vibration* **178**(3): 337–348. [doi:10.1006/jsvi.1994.1490](https://doi.org/10.1006/jsvi.1994.1490).
- Dare, T., Beck, B., Bonness, W.** (2019). Low-frequency pulsation from a package boiler. *Proceedings of 2018 Internoise Impact of Noise Control Engineering*. Chicago, IL U.S.A.
- Daw C.S., Finney C.E.A., Bailey R.T., Flynn T.J., Fuller T.A.** (2002). Real-time monitoring of dynamical state changes in staged combustion. *Proceedings of the ASME 2002 International Mechanical Engineering Congress and Exposition*, Paper No. IMECE2002-39053, 19–22. [doi:10.1115/IMECE2002-39053](https://doi.org/10.1115/IMECE2002-39053).
- Eckstein J., Freitag E., Hirsch C., Sattelmayer T.** (2004). Experimental study on the role of entropy waves in low-frequency oscillations for a diffusion burner. *Proceedings of ASME Turbo Expo*, Vienna, Austria. GT2004-54163. [doi:10.1115/GT2004-54163](https://doi.org/10.1115/GT2004-54163).
- Eckstein J., Freitag E., Hirsch C., Sattelmayer T., von der Bank R., Schilling T.** (2005). Forced low-frequency spray characteristics of a generic airblast swirl diffusion burner. *Journal of Engineering for Gas Turbines and Power* **127**(2): 301–305. [doi:10.1115/1.1789515](https://doi.org/10.1115/1.1789515).

- Eisinger F.L., Sullivan R.E.** (2002). Avoiding thermoacoustic vibration in burner/furnace systems. *Journal of Pressure Vessel Technology* **124**(4): 418–424. [doi:10.1115/1.1462623](https://doi.org/10.1115/1.1462623).
- Eisinger F.L., Sullivan R.E.** (2008). Prediction of thermoacoustic vibration of burner/furnace systems in utility boilers. *Journal of Pressure Vessel Technology* **130**(1): 015002. [doi:10.1115/1.2826459](https://doi.org/10.1115/1.2826459).
- Flynn, T.J., Fuller, T.A., Rufener, S., Finney, C.E.A and Daw, C.S.** (2017). Thermoacoustic vibrations in industrial furnaces and boilers. *Proceedings of AFRC 2017 Industrial Combustion Symposium*, Houston, Texas USA.
- Flynn, T. J., Fuller, T. A., Rufener, S. Finney, C.E.A** (2018). Identifying sources of thermoacoustic vibrations (rumble) in industrial furnaces and boilers. *Proceedings of AFRC 2018 Industrial Combustion Symposium*, Salt Lake City, Utah U.S.A.
- Goldring J.** (2007). More understanding, less hardware: cleaning up at Claus. *Modern Power Systems*, May 2007, 39–43. http://www.rjm-international.com/cms/data/files/pdf/press_cuttings/mps0507claus.pdf.
- Gonzalez-Juez E.** (2017). Modeling thermoacoustic rumble and screech in bluff-body-stabilized combustors. *55th AIAA Aerospace Sciences Meeting*, Gaylord, TX USA. [doi:10.2514/6.2017-0780](https://doi.org/10.2514/6.2017-0780).
- Goy, C. J., James, S. R., Rea, S.** (2005) Monitoring combustion instabilities: E.ON UK’s experience. In *Combustion Instabilities in Gas Turbine Engines: Operational Experience, Fundamental Mechanisms, and Modeling*. Eds. Lieuwen, T. and Yang, V., American Institute of Aeronautics and Astronautics, Reston, VA.
- Han M.** (2008). Sound reduction by a Helmholtz resonator. *Theses and Dissertations*. Paper 1015. Lehigh University.
- Hershman J., Faulkner L.L, Hock M., Rodman C.** (1983). Reduction of combustion-driven acoustic oscillations in a high-pressure steam generator boiler. *Noise-Con 83*, Cambridge, MA USA.
- Iordache V., Catalina T.** (2013). Experimental investigation on the sound pressure level for a high thermal capacity burner during a running cycle. *Applied Acoustics* **74**(5): 708–717. [doi:10.1016/j.apacoust.2012.11.004](https://doi.org/10.1016/j.apacoust.2012.11.004).
- Kodis M., Webster T., Dirks P.** (2002). Multi-faceted inspection and retrofit project improves performance and reduces emissions at El Segundo. *Power Engineering*, July 2002.
- Lifshits V., Londerville S.B.** (1994). Vibration-resistant low NO_x burner. U.S. Patent 5310337.
- Lifshits V., Londerville S.B.** (1995). Vibration-resistant low NO_x burner. U.S. Patent 5460512.
- Nicoud F., Poinsot T.** (2005). Thermoacoustic instabilities: Should the Rayleigh criterion be extended to include entropy changes? *Combustion and Flame* **142**(1–2): 153–159. [doi:10.1016/j.combustflame.2005.02.013](https://doi.org/10.1016/j.combustflame.2005.02.013).
- Parchen R.R., Bruggeman J.C., Aptroot R.** (1996). Burner pulsations in central heating boilers: numerical simulation of burner-boiler interaction and visualization of combustion instability. *Proceedings of International Noise 96*, Liverpool, England.
- Poinsot, T.** (2017). Prediction and control of combustion instabilities in real engines. *Proceedings of the Combustion Institute*, **36**(1), 1–28. doi: 10.1016/j.proci.2016.05.007
- Rayleigh J.W.S.** (1878). The explanation of certain acoustical phenomena. *Nature* **18**(455): 319–321. [doi:10.1038/018319a0](https://doi.org/10.1038/018319a0).
- Richardson E.G.** (1922). The theory of singing flame. *Proceedings of the Physical Society of London* **35**(1): 47. [doi:10.1088/1478-7814/35/1/308](https://doi.org/10.1088/1478-7814/35/1/308).
- Rodriguez-Martinez V.M., Dawson J.R., O’Doherty T., Syred N.** (2006). Low-frequency combustion oscillations in a swirl burner/furnace. *Journal of Propulsion and Power* **22**(1): 217–221. [doi:10.2514/1.12010](https://doi.org/10.2514/1.12010).
- Rott N.** (1983). A simple theory of the Sondhauss tube. *Recent Advances in Aeroacoustics — Proceedings of an International Symposium held at Stanford University, August 22–26, 1983*, 327–338. [doi:10.1007/978-1-4612-4840-8](https://doi.org/10.1007/978-1-4612-4840-8).
- Sams G., Jordan J.** (1996). How to design low-noise burners. *Hydrocarbon Processing* **75**(12).
- Sams G., Jordan J.** (1997). Designing low noise burners inside firetubes. *Applied Acoustics* **51**(2): 121–139. [doi:10.1016/S0003-682X\(96\)00054-0](https://doi.org/10.1016/S0003-682X(96)00054-0).
- Sattelmayer, T., & Polifke, W.** (2003). Assessment of methods for the computation of the linear stability of combustors. *Combustion Science and Technology*, **175**(3), 453–476. doi: 10.1080/00102200302382

Seebold J.G. (2005). Combustion-driven oscillation in process heaters. *IFRF Combustion Journal*, Article Number 200507.

Sewell, J. B., Sobieski, P. A. (2005) Monitoring of combustion instabilities: Calpine's experience, *In Combustion Instabilities in Gas Turbine Engines: Operational Experience, Fundamental Mechanisms, and Modeling*. Eds. Lieuwen, T. and Yang, V., American Institute of Aeronautics and Astronautics, Reston, VA.

Webster T., Bortz S. (2008). Ultra-low NO_x burners can get even better: tougher emission rules are forcing development of even more effective ultra low NO_x burners. *Power Engineering*, November 2008, 144–154.

Whelan, M., Louderville, S. Simplified Analysis and Practical Mitigation Techniques for Industrial Boiler Thermoacoustic Vibration. *Proceedings of American Flame Research Committee 2019 Combustion Symposium*, Kona, Hawaii U.S.A.

Wood S.C. (1994). Select the right NO_x control technology. *Chemical Engineering Progress*, January 1994, 32–38.

Copyright © 2022 The Babcock & Wilcox Company. All rights reserved.

No part of this work may be published, translated, or reproduced in any form or by any means, or incorporated into any information retrieval system, without the written permission of the copyright holder. Permission requests should be addressed to Marketing Communications by contacting us from our website at www.babcock.com.

ACKNOWLEDGEMENT

Portions of this work were performed at Oak Ridge National Laboratory (ORNL) by UT-Battelle, LLC, under Contract No. DE-AC05-00OR22725. The United States Government retains and the publisher, by accepting the article for publication, acknowledges that the United States Government retains a non-exclusive, paid-up, irrevocable, worldwide license to publish or reproduce the published form of this manuscript, or allow others to do so, for United States Government purposes. The Department of Energy will provide public access to these results of federally sponsored research in accordance with the DOE Public Access Plan (<http://energy.gov/downloads/doe-public-access-plan>).

DISCLAIMER

Although the information presented in this work is believed to be reliable, this work is published with the understanding that The Babcock & Wilcox Company (B&W) and the authors and contributors to this work are supplying general information and are not attempting to render or provide engineering or professional services. Neither B&W nor any of its employees make any warranty, guarantee or representation, whether expressed or implied, with respect to the accuracy, completeness or usefulness of any information, product, process, method or apparatus discussed in this work, including warranties of merchantability and fitness for a particular or intended purpose. Neither B&W nor any of its officers, directors or employees shall be liable for any losses or damages with respect to or resulting from the use of, or the inability to use, any information, product, process, method or apparatus discussed in this work.